

Foreword

Thank you for purchasing the Flow Totalizer.

The use's manual contains useful information about the functions of the instrument, installation, operation procedures, parameter setting and troubleshooting . To ensure correct use, please read this manual carefully before installation and operation. And keep this manual in a safe place for quick reference in the event a question arises.

Packing Details

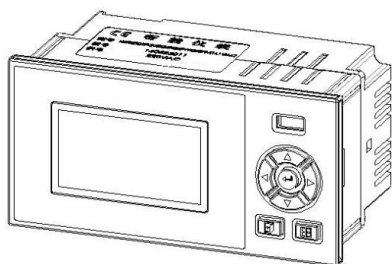

Flow Totalizer

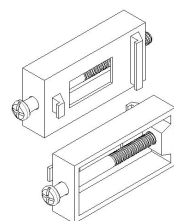

Mounting Bracket

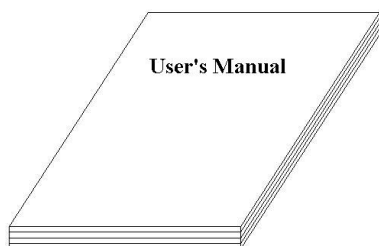

User's Manual



Quality Certification

No.	Name	Unit	QTY	NOTE
1	Flow Totalizer	pcs	1	
2	Mounting Bracket (with screws)	pcs	2	Suit for embedded instainstallation mode
3	User's Manual	book	1	
4	Quality Certification/ Warranty Card	pcs	1	
5	RS232C/485 Convert Modula	pcs		optional
6	RS232C Lines	pcs		optional

Attention

- **If you find that the instrument is damaged by transportation, please contact the manufacturer.**
- **This series of instruments is suitable for general industrial occasions. If you have special use requirements, please set up a separate protective device.**
- **For the safety of you and the instrument, please do not install with electricity. Please use the rated voltage power supply, the correct wiring, properly grounded, after the power supply, please do not touch the back of the instrument wiring terminal, in case of electrical shock.**
- **The instruments should be installed indoors, and the installation position is to ensure that the ventilation is smooth (in case the temperature inside of the instrument is too high), avoid the wind, rain and direct sunlight, do not install in the following situations:**
 - **An occasion where temperature and humidity exceed the conditions of use**
 - **An occasion in which a corrosive, flammable or explosive gas is present.**
 - **Occasions with large amounts of dust, salt and metal powder.**
 - **Occasions where water, oil and chemical liquids are easily spattered.**
 - **An occasion of direct vibration or shock.**
 - **Electromagnetic source.**
- **The instrument should take appropriate shielding measures when it is close to power line, strong electric field, strong magnetic field, static electricity, noise or AC contactor, etc.**
- **In order to avoid measuring error, when the sensor is thermal resistance, use three copper conductors of the same size and resistance value less than $10\ \Omega$, otherwise the measurement error will be caused.**
- **In order to extend the service life of the instrument, please carry out regular maintenance and maintenance. Do not repair and disassemble the instrument by yourself. When wiping the instrument, please use a clean soft cloth, do not dip in alcohol, gasoline and other organic solvents cleaning, may cause discoloration or deformation.**
- **If the meter has influent, smoke, smell, noise and so on, please immediately cut off the power supply, stop using and get in touch with the supplier or our company in time.**

Catalogue

CHAPTER 1: SUMMARY	4
CHAPTER 2 TECHNICAL INDICATORS	5
CHAPTER 3 INSTALLATION WIRING	7
3.1 INSTRUMENT STRUCTURE	7
3.2 INSTRUMENT DIMENSIONS	7
3.4 INSTRUMENT INSTALLATION	8
3.5 INSTRUMENT WIRING	8
3.5.1 WIRING METHODS	8
3.5.2 TERMINAL DESCRIPTION	9
3.5.3 WIRING DIAGRAM	10
CHAPTER 4 BASIC OPERATION AND RUNNING PICTURE	11
4.1 INSTRUMENT KEYS	11
4.2 STATUS MARKERS	11
CHAPTER 5 PARAMETER SETTINGS AND AUXILIARY	13
5.1 CONFIGURATION LOGIN AND SYSTEM CONFIGURATION	13
5.1 FLOW CONFIGURATION	14
5.2 TEMPERATURE AND PRESSURE CONFIGURATION	16
5.3 OUTPUT CONFIGURATION	17
5.4 ALARM CONFIGURATION	17
5.5 COMMUNICATIONS CONFIGURATION	18
CHAPTER 6 FAULT ANALYSIS AND TROUBLESHOOTING	19
CHAPTER 7 FAULT ANALYSIS AND TROUBLESHOOTING	20

Chapter 1: Summary

● Summary

The sophisticated flow totalizer is based on ARM microprocessors, can match to all the flow transmitter sensor. It collects, displays, controls, transmits and communicates all kinds of signals such as temperature, pressure and flow, widely used in petrochemical, chemical, trade settlement and factory metering management network in metallurgical, electric power, light industry, pharmaceutical and city gas industries.

● Feature

◎Suit for flow meters and fluid media.

◎Automatic conversion of flow unit and automatic calculation the flow coefficient of differential pressure flowmeter.

◎Steam density is calculated by IAPWS-IF97 formula, and the overheating and saturation state of steam is automatically identified.

◎Emergency fault tolerance function: when temperature and pressure signal are abnormal, use emergency parameter value for compensation calculation.

◎Debugging function: support to view the original value of each transmitter/sensor signal;Support to view the flow Intermediate parameters during calculate such as density are used in the calculation.

◎Audit Record: blackout record function

◎Alarm List: Support recording instantaneous quantities or cumulative alarm information of flow rate, temperature, pressure, differential pressure/frequency/volume/mass.

◎Cumulative Report: support cumulative flow shift report, daily report, monthly report, annual report.

◎Communication function: standard Modbus RTU protocol, supports RS485 and RS232C communication interface.

◎Transfer Function: Standard current transformer is supported, signal source channel is optional.

◎Report backup function: support each cumulative report backup function.

◎Import and export function: support import and export function of instrument configuration parameters.

◎Timing printing function: support flow, temperature, pressure, accumulation and other data timing printing function.

Chapter 2 Technical Indicators

● Display

Screen: The monochrome flow integrator uses a 128 * 64 dot matrix monochrome liquid crystal display (LCD)

The 3.5-inch color flow integrator uses a 362 * 272 dot matrix color LCD display (LCD)

The 4.3-inch color flow integrator using 480 * 272 dot matrix color LCD display (LCD)

Accuracy: Display and measurement accuracy $\pm 0.2\%$ F.S.

● Processor

High performance arm Cortex-M3 32 bit RISC core.

● Input Function

Flow Channel: Analog signal: 0-10mA, 4-20mA Frequency signal: Fr(range: 0.0-5000.0HZ, Vil: $\leq 1V$, Vih: $\geq 5V$)

Temperature channel: 0-10mA, 4-20mA, Pt100

Pressure channel: 0-10mA, 4-20mA

Attention

Other input signals (such as switch input (DI), need to be indicated when ordering.

● Output Function

Distribution Output: Provide 1 group (F12) 12VDC and 2 groups (Q24, P24) 24VDC sensor power supply.

Transmission Output: support 1 channels standard current output, load capacity 500 Ω (maximum).

Relay output: Support up to 3 relay output, contact capacity 3A@ 250VAC / 3A@ 30VDC, can be configured upper limit HH / upper limit HI/ lower limit LO / lower limit LL .

● Communication Function

Communication Interface: providing RS232C and RS485 communication interfaces for users to choose from, supporting Modbus RTU protocol, baud rates- (1200/4800/9600)

Print interface: RS232C direct connection to micro printer, baud rate 1200.

● Report Backup

Report backup and transfer: Support USB 1.1, 2.0 protocol, support from 1G to 32G U disk for cumulative report transfer, strong compatibility, compatible with most of the market U disk.

● Power Supply

AC Power supply: 220VAC/50HZ AC power supply, DC Power supply: 24VDC (18VDC-36VDC) DC power supply, 12VDC (9VDC-18VDC) DC power supply (DC power supply to be indicated when ordering).

Attention

● Error Precision

Clock error: ± 2 seconds / day

- **Working Environment [prohibited from working in flammable, corrosive]**

Working temperature: 0 °C 50 °C (avoid direct sunlight)

Relative humidity: 0 / 85R.H (without condensation) Altitude: < 2000m (other than special specifications).

- **Instrument Net Weight**

Net weight: ≤ 1.0 kg

Attention

©The technical index is the general index of this series instrument, the function configuration please take the material object as the standard.

©If the technical index is inconsistent with the physical instrument , please take the object in kind .

Chapter 3 Installation Wiring

3.1 Instrument Structure

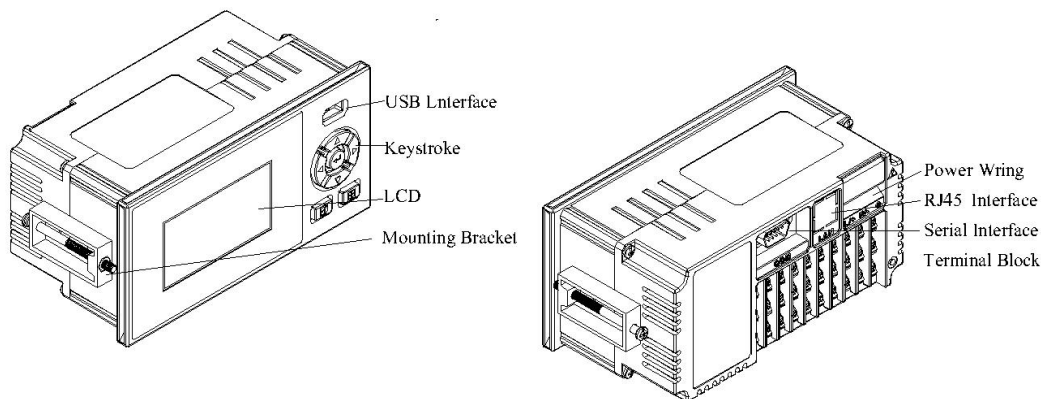

3.2 Instrument Dimensions

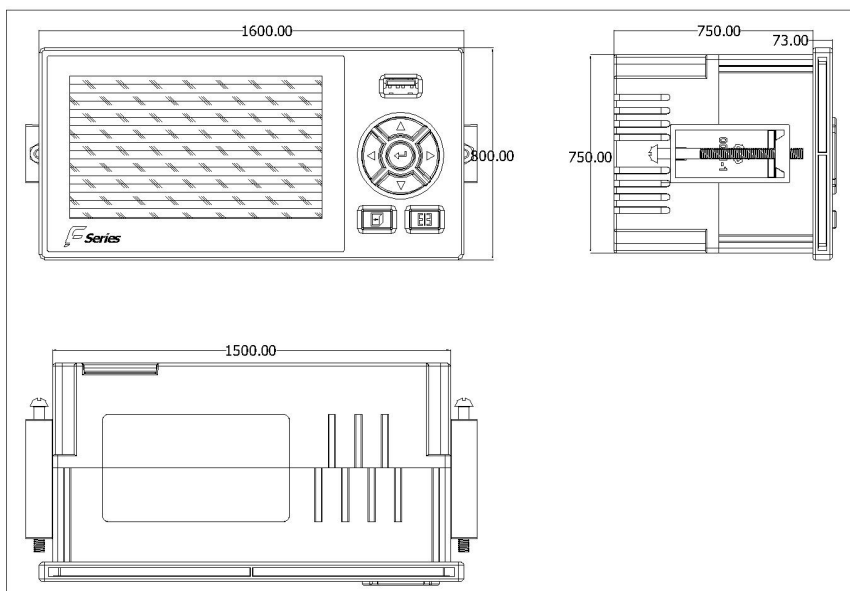

The above graphic unit: mm

3.3 Size Of Opening

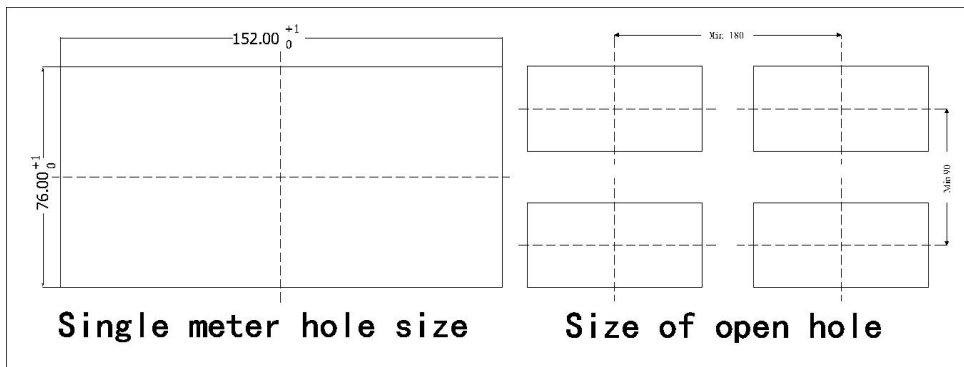

When assembling the meter, refer to the minimum spacing between meters recommended in the above table to ensure the necessary heat dissipation and loading and unloading space.

3.4 Instrument Installation

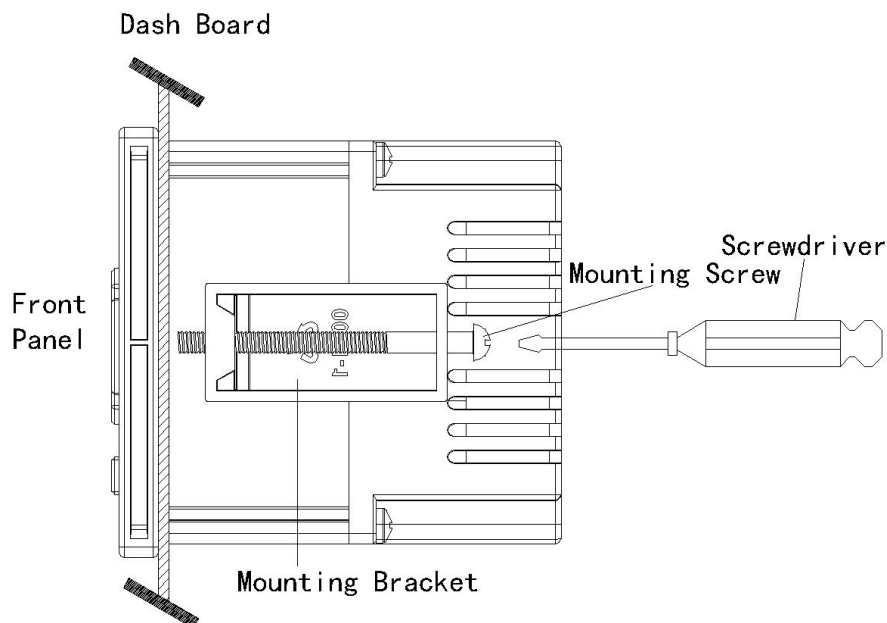

Installation Method:

- ◎ Step 1: push the meter into the installation hole from the front of the mounting panel (please use the steel plate). The thickness of the mounting panel is (1.5 ~ 6.5) mm.
- ◎ Step 2: install the mounting bracket with the instrument as shown above (two supports on both sides of the instrument and M4 standard screw for the instrument panel mounting bracket).
- ◎ Step 3: after the meter body is installed, the signal line and power line can be connected.

3.5 Instrument Wiring

3.5.1 Wiring Methods

U-type voltage terminal with insulated sleeve (M 3.5 screw for power terminal and M 3 screw for signal terminal) is recommended.



In order to improve the safety of the instrument, please follow the following warning when wiring.

Attention

- ◎ To prevent electrical shock, make sure the power supply is cut off before connecting.
- ◎ To prevent fire, please use double insulated wires (lines with cross sectional area $\geq 1\text{mm}^2$; Insulated wire 600V; conductors with high voltage resistance and cross section $\geq 0.5\text{mm}^2$).
- ◎ Please set the air switch in the power supply loop to separate the table from the total power supply.
- ◎ Tighten the terminal screw firmly.
- ◎ After the power line is connected, the power supply should be connected to check whether the instrument is normal or not. Please do not connect the signal line until it has been confirmed that the instrument can work normally, and then disconnect the power supply and carry on the connection of the signal line.
- ◎ The measuring circuit and the power circuit need to be laid separately, the object of measurement should not be an interference source, once it is unavoidable, please insulate the measuring object from the

measuring circuit, and grounding the measuring object.



©For electrostatic interference, the use of shielding lines is better.

©For the interference caused by electromagnetic induction, it is better to equip the measuring circuit with equal distance.

©If the input wiring is connected in parallel with other instruments, the measurement value will be affected. Be careful not to switch off the power supply of one of the instruments when you have to run in parallel. This will have a negative impact on other instruments. The thermal resistance cannot be paralleled in principle, and the current signal can not be parallel in principle.

©Platinum resistance input should be less than 10 Ω per lead resistance (lead resistance value is the same).

3.5.2 Terminal Description

Terminal name	Explain
L/+、N/-、  +、-、NC	L is the AC power source phase line end, N is the AC power source zero end,  is the ground end, + is the DC power source positive end, - is the DC power supply negative end, the DC power supply, please indicate when ordering.
A+、B-	Signal transmitter, receiver, and communication ground of RS485 communication interface
R1、R2、R3	Relay output port 250VAC /3A@30VDC/3A
F+、F-、F12	Signal end of frequency flowmeter, signal end, 12VDC feed input end
AO+、AO-	The positive and negative end of the current output
Q+、Q-、Q24	Signal end of differential pressure flowmeter, signal end, 12VDC feed input end
TA、TB、TC	Temperature channel analog input terminal (TA, TB, TC);Temperature transmitter (electricity Signal end (TB), signal end (TC)
P+、P-、P24	Signal end of pressure transmitter (current) (P+), signal end (P-), 24VDC feed input (P24)
COM	RS232C communication interface / serial port print interface (where 2 feet are RXD instrument signal receiving terminal and 3 pin is TXD instrument signal transmitter terminal 5 pin is signal ground end)
LAN	Ethernet RJ45 interface

Note: Touching the terminal while electricity are strictly prohibited

3.5.3 Wiring Diagram

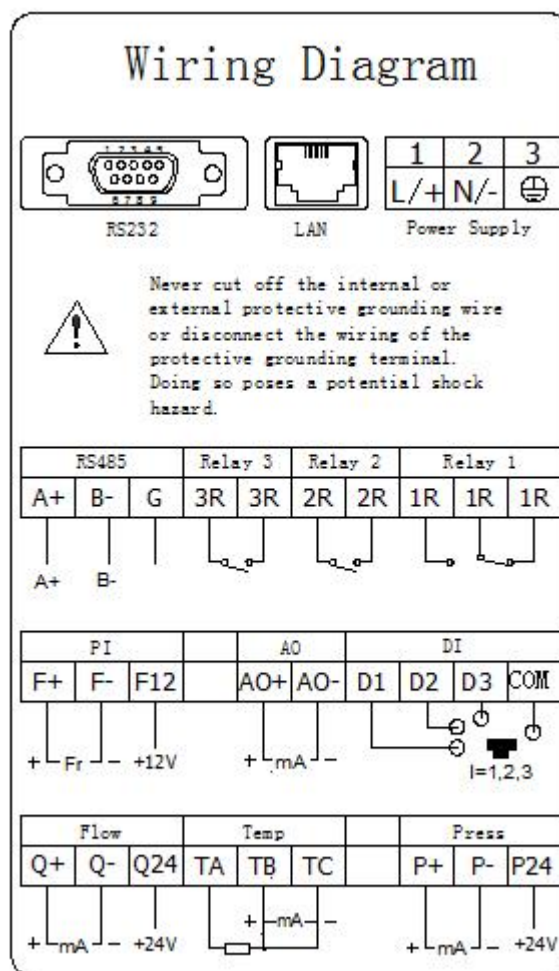

Attention

- ©The power supply voltage at the project site shall be limited to the withstand voltage range of the instrument.
- ©This machine often opens the factory by default, the other way to leave the factory please indicate when ordering.
- ©Please do not plug and pull the communication cable, if you need to operate, do it after the power supply of the instrument is off.
- ©If the wiring diagram is inconsistent with the physical instrument , please take the object in kind .

Chapter 4 Basic Operation and Running Picture

4.1 Instrument Keys

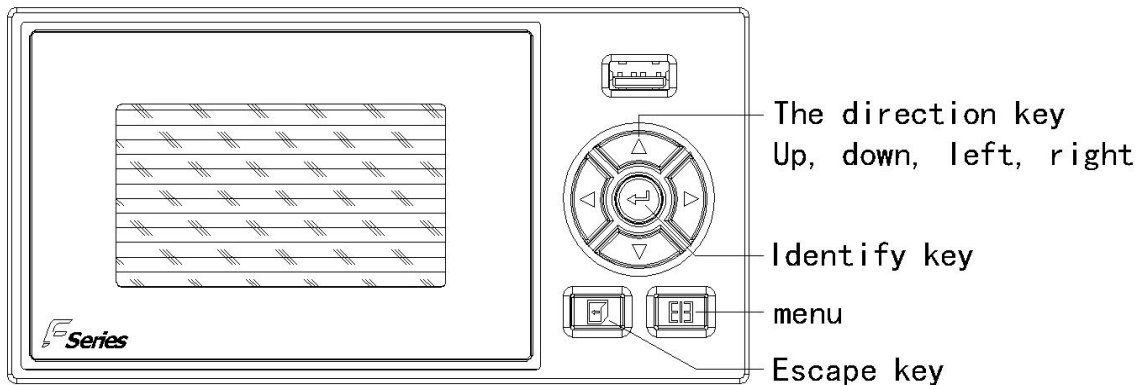

Keyboard Function

- ◎ Upward key: Switch to select or increase cursor data values, etc.
- ◎ Down key: Switch to select or reduce cursor values, etc.
- ◎ Left key: Switch channels or move the cursor forward, etc.
- ◎ Right key: Switch timescale or move back cursor, etc.
- ◎ Confirmation key: Perform cursor location function or edit cursor location data, etc.
- ◎ Escape Key: Exit the current screen.
- ◎ Menu key: Switch main display pages, etc.
- ◎ Escape+Menu Combination key: Hold down more than 1 second at the same time, enter the configuration Interface.

4.2 Status Markers

■ Overview Appearance

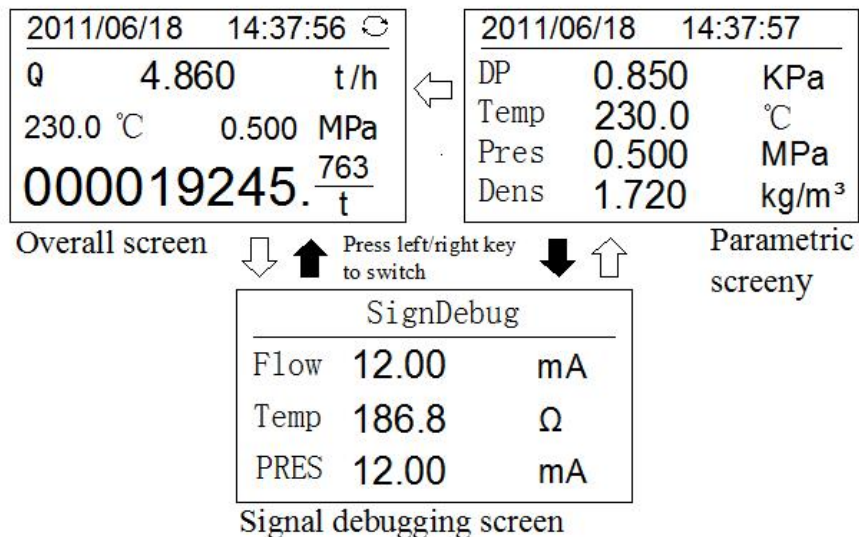

■ Bar Graph Photo

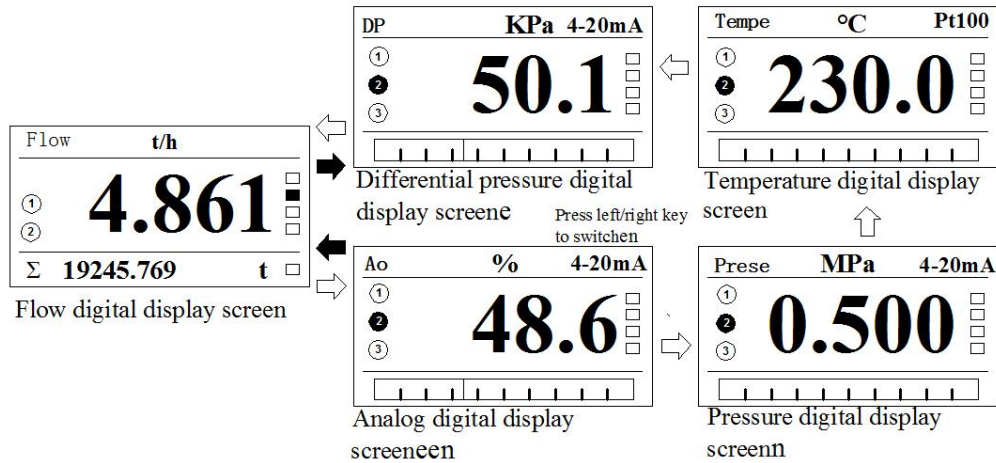

■ Query interface

Press [Entry] key to enter the sub-function screen

<p>DayCum Flow 19-04-30</p> <p>04-30:112.31</p> <p>05-01:115.60</p> <p>05-03:118.77</p> <p>Σm:1804.05 t</p> <p>Daily cumulative report</p>	<p>ClassCum Flow 11-06-15</p> <p>1Class:42.95</p> <p>2Class:37.44</p> <p>3Class:31.92</p> <p>Σd:112.31 t</p> <p>Class cumulative report</p>	<p>03 06/09 19:55:03 QF</p> <p>06/09 20:27:49 HH</p> <p>04 06/09 20:38:25 T</p> <p>06/09 21:41:36 LL</p> <p>05 06/09 23:08:11 P</p> <p>06/09 23:12:01 LO</p> <p>Alarm list screen</p>									
<p>Demand</p> <table border="1"> <tr><td>Days</td><td>Clas</td><td>AlM</td></tr> <tr><td>Mont</td><td>BCK</td><td>Pow</td></tr> <tr><td>Year</td><td>TBP</td><td>Msg</td></tr> </table> <p>Function query screen</p>	Days	Clas	AlM	Mont	BCK	Pow	Year	TBP	Msg	<p>MothCum Flow 11-06</p> <p>11-04:3499.935</p> <p>11-05:3511.266</p> <p>11-06:1804.053</p> <p>Σy:19245.782 t</p> <p>Monthly cumulative report</p>	<p>USB</p> <p>Report</p> <p>File 0614151.XLS OnLi</p> <p>Rset</p> <p>Report backup screen</p>
Days	Clas	AlM									
Mont	BCK	Pow									
Year	TBP	Msg									
<p>Press [Exit] key to exit the sub-function screen</p> <p>YearCum Flow</p> <p>09:0.000</p> <p>10:152.427</p> <p>11:19245.794</p> <p>Σ:19398.221 t</p> <p>Annual cumulative report</p>	<p>MSG-List</p> <p>VER YF30V3.0.1X</p> <p>Information list screen</p>	<p>03 11/06/13 09:42:46</p> <p>11/06/13 09:45:07</p> <p>04 11/06/14 08:50:25</p> <p>11/06/14 08:51:36</p> <p>00006/0000020M</p> <p>Power off list screen</p>									

Monochromatic flow integrator

Press [Entry] key to enter the sub-function screen

<p>DayCum Flow 11-06-14</p> <p>06-13:112.31</p> <p>06-14:115.60</p> <p>06-15:118.77</p> <p>Σm:1804.05 t</p> <p>Daily cumulative report</p>	<p>ClassCum Flow 11-06-13</p> <p>1Class:42.95</p> <p>2Class:37.44</p> <p>3Class:31.92</p> <p>Σm:1804.05 t</p> <p>Class cumulative report</p>	<p>47.0 11-03-24 13:37:53</p> <p>Remembrance list screen</p>
<p>Dyas Clas AIM</p> <p>Moth BCK Pow</p> <p>Year TBP Msg</p> <p>Fuction query screen</p>	<p>MothCum Flow 11-06</p> <p>11-04:3499.935</p> <p>11-05:3511.266</p> <p>11.06:1804.053</p> <p>Σy:19245.782 t</p> <p>Monthly cumulative report</p>	<p>Backup query</p> <p>Cumulative report Xsl</p> <p>Historical data BIN</p> <p>Historical list CSV</p> <p>Report backup screen</p>
<p>Press [Exit] key to Exit the sub-function screen</p> <p>YearCum Flow</p> <p>09:0.000</p> <p>10:152.427</p> <p>11:19245.794</p> <p>Σ:19398.221 t</p> <p>Annual cumulative report</p>	<p>Timed printing</p> <p>Manner timing</p> <p>Interval 1 Min</p> <p>Printing... Open</p> <p>Timed printing screen</p>	<p>Pow list</p> <p>Sum rep Ver info</p> <p>His data</p> <p>Config logs Exit</p> <p>Pow list screen</p>

3.5-inch and 4.3-inch color flow integrators

Chapter 5 Parameter Settings and Auxiliary

5.1 Configuration Login and System Configuration

```
Pass: 00 00 00*
Sys   Flow   Temp
Pres  Output ALM
Comm  Ctrl   Func
```

Configuration screen

```
Time 19-04-30 14:40:29
Pass 00 00 00
Patr 0 S   SysMaint
ATM  101.325 kPa
Exit
```

System configuration

Monochromatic flow integrator

```
00 Sys   Flow   Temp
00 Pres  Output ALM
00
[lock] Comm Heat   Func
```

Configuration screen

```
Time 11-06-18 14:40:29
Pass 00 00 00 Inter 60S
TourDis 0 S   Calibre 0mm
ColSid 32°C
AtmoPres 101.325 KPa
System maintenance
Exit
```

System configuration

3.5-inch and 4.3-inch color flow integrators

Configuration Login

©At the same time, hold down [Menu] key and [Entry] key one second later, enter the configuration login screen, enter the correct password to enter the configuration screen, Then select the corresponding sub-configuration entry configuration settings, password errors can not enter the configuration screen, the picture description as shown in the figure.

©The default initial password for operator permissions is 00 00 00.

System Configuration

©Time: Set system date and time.

©Pass: administrator permissions login configuration to modify or view parameters of the unique password, the initial default 00 00 00.

©Patr: cycle displays the time period value of each display combination screen.

©SysMaint: The system maintenance function, such as [clear the power off list] or [clear the alarm list] or [restore the default setting]. Once system maintenance is confirmed, the data will be cleared or factory settings will be restored, the process will not.

©ATM: atmospheric pressure.

Attention

©The operation and management password is the only password that can enter the configuration modification parameter. It is suggested that the user should modify the password as soon as possible after purchasing the instrument and keep it properly.

© Factory settings will initialize all configuration information and clear all stored data in the instrument, including historical data, power loss list, alarm list, etc.

5.1 Flow Configuration

Mode	DP	Diffpres
Unit	t/h	Medium
RGE	10.000	Num 3
K	1000.000	Auto
Cum		Exit

Differential pressure model

Mode	Freque	Freque
Unit	t/h	Medium
RGE	10.000	Num 3
K	10475.950	$\mu\text{L}/\text{m}^3$
Cum		Exit

Frequency type model

Mode	Linear	Linear
Unit	t/h	Medium
RGE	10.000	Num 3
K	1.000	
Cum		Exit

Linear model model

Type	4-20mA	Sqrt	Self
unit	KPa	F	0 S
DF	1	Adj	0.5
RGE	0.0	~	100.0
Cut	0.0 %		Exit

Differential Pressure Configuration

Type	Fr
Unit	Hz
Cut	10.0 Hz
	Exit

Frequency configuration

Type	4-20mA	F	0 S
Unit	m³/h	Adj	0.5
DF	1	~	100.0
RGE	0.0		
Cut	0.0 %		Exit

Linear configuration n

© Mode:

© DP: difference pressure flow meter: $Q = K * \sqrt{\Delta P * \rho}$

K : Flow coefficient ΔP : Input differential pressure value ρ : Dielectric density

© Freque: Vortex Flow meter: $Q = 3600 * I_f * \rho / K$

K : Flow coefficient I_f : Vortex frequency ρ : Dielectric density

© Linear: Linear Flow meter: $Q = K * \rho * \Delta P$

K : Flow coefficient ΔP : Linear signal (volume value) ρ : Dielectric density

© Diffpres/Freque/Linear:

© Sqrt: Choosing whether the square-setting algorithm is computed locally.

© F: The setting of filtering time helps to improve the smoothness of the signal. The longer the filter time is, the smoother the signal is, but the slower the response is.

© DP: the volume of the channel shows a decimal point.

© Cut: When the measurement signal is small, the measurement error is relatively large, especially below 1%, the accuracy will be greatly reduced, and the project will generally be zeroing, i.e. cutting off the small flow. When setting a certain percentage, the signal less than the range percentage is forced to be the lower limit of the range.

© Flow Unit:

kNm³/h, Nm³/h, km³/h, kNm³/h, m³/h, m³/min, m³/s, L/h, L/min, L/s, mL/h, mL/min, mL/s, t/h,

t/min, t/s, kg/h, kg/min, kg/s.

©Medium: The flow rate of fluid is proportional to the density of fluid. In order to accurately measure the flow rate of fluid, the density of fluid must be compensated. Most of the density of fluid varies with the pressure and temperature of working conditions. Therefore, the compensation of fluid density can be converted into temperature and pressure compensation of fluid. According to different fluid media, the medium compensation methods are divided into: non-compensation, general gas, saturated steam, superheated steam and natural gas.

Modium DisComp Dens 1000 kg/m3 Show Clos Exit	Modium GAS StdD 1000 kg/m3 ST 20.00 °C Exit	Modium SHS ST 20.00 °C Exit
---	---	--

©DisComp: No compensation. When the system does not have temperature and pressure compensation, the density is fixed at 1.000kg / m by default.

©GAS: General gas. The purpose of general gas compensation is to convert the working condition volume into the volume flow rate under the standard condition.

The equation of state of general gas accords with the equation of state of ideal gas, and the relation between the density of working condition and the density of standard condition accords with the following

formula:

$$\rho_f = \rho_n * \frac{(273.15 + T_n)(0.10136 + P_f)}{(273.15 + T_f)(0.10136 + P_n)}$$

Standard temperature $T_n = 20.00\text{ }^\circ\text{C}$, Standard pressure $P_n = 0.000\text{Mpa}$

T_f : Operating temperature, P_f : Working pressure (gauge pressure)

©SHS: Saturated Steam. The purpose of compensation for saturated steam is to obtain mass flow. According to the saturated steam pressure (or temperature) density meter to find the working condition density, realize the pressure (or Temperature) compensation. At this point, the density in the orifice plate of the flow model is input according to the actual input. Pressure (or temperature) density obtained by checking saturated steam pressure (or temperature) density table.

©STS: Superheated Steam. The purpose of compensation for superheated steam is to obtain mass flow.

The temperature and pressure compensation is realized by checking the working condition density according to the superheated steam density meter.

©Natgas: Natural Gas. The purpose of natural gas compensation is to convert the working condition volume into the volume flow rate under the standard condition. The relation between the working condition density and

the standard density conforms to the following formula:

$$\rho_f = \rho_n * \frac{(273.15 + T_n)(0.10136 + P_f)}{(273.15 + T_f)(0.10136 + P_n)} * \frac{Z_n}{Z_f}$$

Standard temperature $T_n = 20.00\text{ }^\circ\text{C}$, Standard pressure (gauge pressure) $P_n = 0.000\text{Mpa}$

T_f : Operating temperature, P_f : Working pressure (gauge pressure),

Z_n : For the compressibility of natural gas in the standard state , Z_f : coefficient of natural gas in flowing state.

◎ **Flow K:**

◎ When the model is selected as [Diffpres], the coefficient of flow meter is:

$$K = \frac{Q}{\sqrt{\Delta P * \rho}}$$

◎ When the model is selected [Freque], the unit of flow coefficient is time/m3 by default, and the unit and coefficient value of instrument coefficient are set to the unit and coefficient value of Flowmeter (if the Flow meter unit is time/L, the instrument coefficient = Flowmeter coefficient is 1000).

◎ When the model is selected [Linear], When the medium is not compensated, the volume upper limit is set to the flow value corresponding to the upper limit of linear signal, and the lower limit is set to 0. Both the flow and density takes part in the calculation, When the medium is compensated, the density takes part in the calculation, and the flow coefficient is calculated according to the calculation formula of linear Flowmeter.

◎ **Flow Cum:**

◎ CumuUnit: Nm3, m3, L, mL, t, kg.

◎ ShifTime: First shift start time, 0-11 o'clock can be grouped.

◎ ShifDura: The length of each shift can be grouped at 8:00 (Class 3) and 12:00 (Class 2).

◎ CumValu: Set the Cumulative Initial Value of Flow, the maximum can be set to 99999999.

◎ CLR: Cumulative Zero Clearing. Clear all previous accumulated data, including the cumulative value in the general picture/digital display screen, the class accumulation in the query screen, the daily accumulation, the monthly accumulation, the annual accumulation report, please operate with caution.

5.2 Temperature and Pressure Configuration

Mode	Ext	Type	Pt100
Unit	°C	F	1 S
DF	1	Adj	0.0
RGE	-99.9 ~ 850.0		
Cut	0.0	%	Exit

Temperature external compensation configuration

Mode	Ext	Type	4-20mA
Unit	MPa	F.	0 S
DF	3	Adj	0.000
RGE	0.000 ~ 1.000		
Cut	0.0	%	Exit

Pressure external compensation configuration

Mode	Set	
SetVal	20.0	°C
		Exit

Temperature given configuration

Mode	Set	
SetVal	0.600	MPa
		Exit

Pressure given configuration

◎ **Mode:** When the temperature/pressure compensation is input from the external sensor, the mode chooses [Ext]. When given by the internal, the given temperature/pressure value should be set at [Set].

5.3 Output Configuration

Chnl	04	Type	4-20mA
REL	N		
N	0.000	~	99999.99
SignSour	Flow		
Exit			

Output configuration

Chnl	04	Type	4-20mA
REL	N		
N	-200.0	~	850.0
SignSour	Temp		
Exit			

Output configuration

©type: The output signal type selection of the transmission output channel.

©REL: under the positive action, the upper limit of the transmission range corresponds to the upper limit of the output current, the lower limit of the transmission range corresponds to the lower limit of the output current when the default range of transmission is positive, and the upper limit of the range of transmission corresponds to the lower limit of the output current under the counter action. The lower limit of the range corresponds to the upper limit of the output current.

©N: the upper and lower limits of the transmission and output range of the signal source channel [sampling channel] defined by the user.

©SignSour: The source sampling channel that specifies the output value of the current transmit output channel.

5.4 Alarm Configuration

Alam	
Diff	Flow
Temp	Cum Flow
Pres	Exit

Alarm configuration

HH:	850.0	Cont:	No
HI:	435.0	Cont:	01
LO:	46.0	Cont:	No
LL:	-99.9	Cont:	No
Dela:	1.0%	Exit	

Alarm configuration-Instantaneous value

FlowCumu	
AlarmHi:	9000.000
Cont:	01
Exit	

Alarm configuration-cumulative value

©Alarm configuration contains alarm threshold, alarm contact, alarm return difference and other parameters, the parameters are described as follows:

©Alarm threshold: the threshold produced by the alarm, which must be within the range of the channel range. This instrument is divided into four categories: upper limit (HH), upper limit (HI), lower limit (LO) and lower limit (LL).

©Alarm Cont: relay number, such as contact 01 for relay 01, that is, R1(display in instrument screen) or K1 (display in instrument wiring mode).

©Alarm Dela: when the signal oscillates near the alarm threshold, the relay acts frequently, which sets a difference (lag) for the occurrence and release of the alarm.

5.5 Communications Configuration

Mode	PC	Addr	001
Stop	2 B	GKS	Even
Baud	19200		
			Exit

Communication Configuration—PC

© Mode: including PC and printer two ways to enter the print configuration must first set the online mode as a printer to be effective.

© Addr: the communication address is used to distinguish when the instrument is made up of the network. It is the identity of the instrument in the network. The host computer software is used to access the instrument. The local address of the same communication network can be set between 001 and 255, and it can not be repeated.

© Baud: when the communication mode is 'printer' mode, baud rate can not be changed. PC ways, baud rate can be changed(1200、4800、9600)

© GKS: no check / odd check / even check, default odd check.

© Stop: 2 bit / 1 bit, default 2 bit.

RS485 connection mode

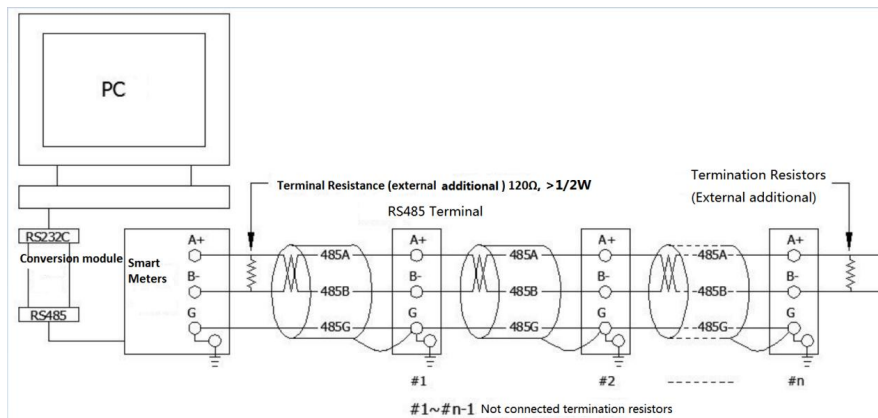

RS232 connection mode

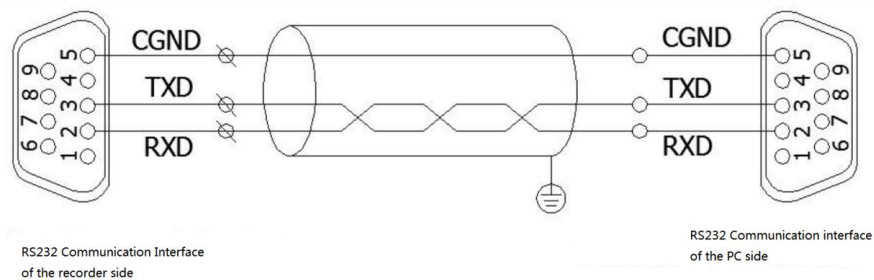

Chapter 6 Fault Analysis and Troubleshooting

The paperless recorder adopts advanced production technology and carries out strict test before leaving the factory, which greatly improves the reliability of the instrument. Common failures are generally caused by improper operation or parameter setting. If you find a failure that can not be handled, please record the failure and contact us in time. The following are some troubleshooting and handling measures for this instrument in its daily application:

Fault Phenomenon	Cause Analysis	Solution
The recorder not working with electricity	①Poor contact with power cord ②Power switch is not closed	Check power supply
The signal display does not match the actual situation	①Signal setting error in configuration ②wiring error	①Inspection configuration ②Check signal line
Alarm Output Abnormal	①Alarm limit setting error ②Alarm points shared by other channels	①Reset the limit ②Cancel other alarm points
Problems in distribution output	①Transmitter and instrument wiring error ②Power distribution with multiple transducers exceeding the standard distribution of this instrument ③Interference between digital and analog signals during distribution	①Correct wiring ②Use external voltage stabilizer to supply power ③Use independent power supply
USB Transfer Failure	①Incorrect start and end time settings ②U disk format is incorrect ③U disk incompatibility ④Insufficient spare space on U disk ⑤Misoperation during backup	①Setting time correctly ②Format U disk to FAT32 ③Use a genuine compatible U disk ④Use larger capacity U disk or clear redundant files in U disk. ⑤proper operation
No data or abnormal display in USB transfer file	①No data for the time period selected by the user ②User changed system time ③User changed signal type ④The user sets the record interval too big, but the backup time is very short ⑤U disk incompatibility ⑥The time period of the data is too long, which exceeds the maximum read time domain of the upper computer software.	①Select the time to have a data segment ②》Erasing the primary data area ③No impact on data recording ④Record interval is set to be small or backup time is longer ⑤Use a genuine compatible U disk ⑥The time period for backing up the data is smaller, piecewise and batch backup
Variable output Problem	①Variable output	①Check the signal source

Chapter 7 Fault Analysis and Troubleshooting

Dear user: Hello! Thank you for choosing our instrument. Our company will thank you for your trust in our company with high-quality service. When using this instrument for the first time, first check whether the actual configuration of the product is consistent with the instrument configuration list, and whether the packed items such as accompanying data and accessories are complete. If you have any objection, please contact us first.

■ **Precautions**

- Read the attached materials: please carefully read the attached materials and warranty principles, and store them completely.
- After purchasing the machine, keep the purchase invoice properly.

Warranty principle:

■ **maintenance cycle**

Five working days from the date of receipt of the product.

■ **maintenance costs**

- The free warranty period of this series of exquisite flow totalizer is one year (product quality problem).
- The warranty period is calculated from the date of purchase by the user, and is evidenced by the user's purchase invoice (indicating the product model and host serial number) or a copy. If the invoice cannot be provided, it shall be calculated from the date of our company's production.
- During the warranty period, products damaged due to improper use by

the customer, or the customer has opened the qualified seal of the product, will be charged a certain fee. After the product is repaired, it can be guaranteed for another half a year free of charge.

■ **instructions to customers**

- Please be sure to send the product back with the product fault description to help the engineer repair it as soon as possible.
- Please fill in the telephone / fax number, mailing address and contact person accurately for the return of maintenance products.
- If you want the engineer to go to the site for maintenance, you must bear the costs incurred.
- The company usually sends it back by express (without insurance). If it needs to be transported by other parties, please indicate it in the form and pay the relevant fees.

